

Technical data sheet

Wall and support bracket AW 15



Light-duty wall and support bracket with welded head plate.

Fastening of the bracket to the U support of width 400 mm or greater using hexagonal bolt through both sides of the support. Please insert suitable spacers.

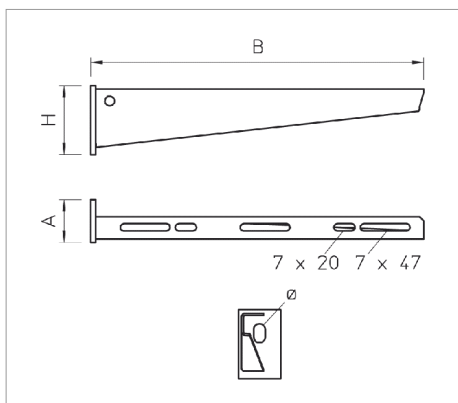

Type	Width mm	Dimensi on H mm	Dimensi on A mm	Hole diameter mm	F in kN kN	Pack. pcs	Weight kg/100 pcs.	Art.-No.
AW 15 11 FT	110	50	40	11	1.5	30	14.500	6420656
AW 15 16 FT	160	55	40	11	1.5	30	21.000	6420664
AW 15 21 FT	210	60	40	11	1.5	30	26.000	6420680
AW 15 31 FT	310	65	40	11	1.5	30	32.500	6420710
AW 15 41 FT	410	70	40	11	1.5	30	55.000	6420745
AW 15 51 FT	510	75	40	11	1.5	20	72.000	6420788
AW 15 56 FT	560	80	40	11	1.5	20	77.000	6420796
AW 15 61 FT	610	80	40	11	1.5	20	85.000	6420826



St Steel

FT Hot-dip galvanised

R /pc.

Load diagram

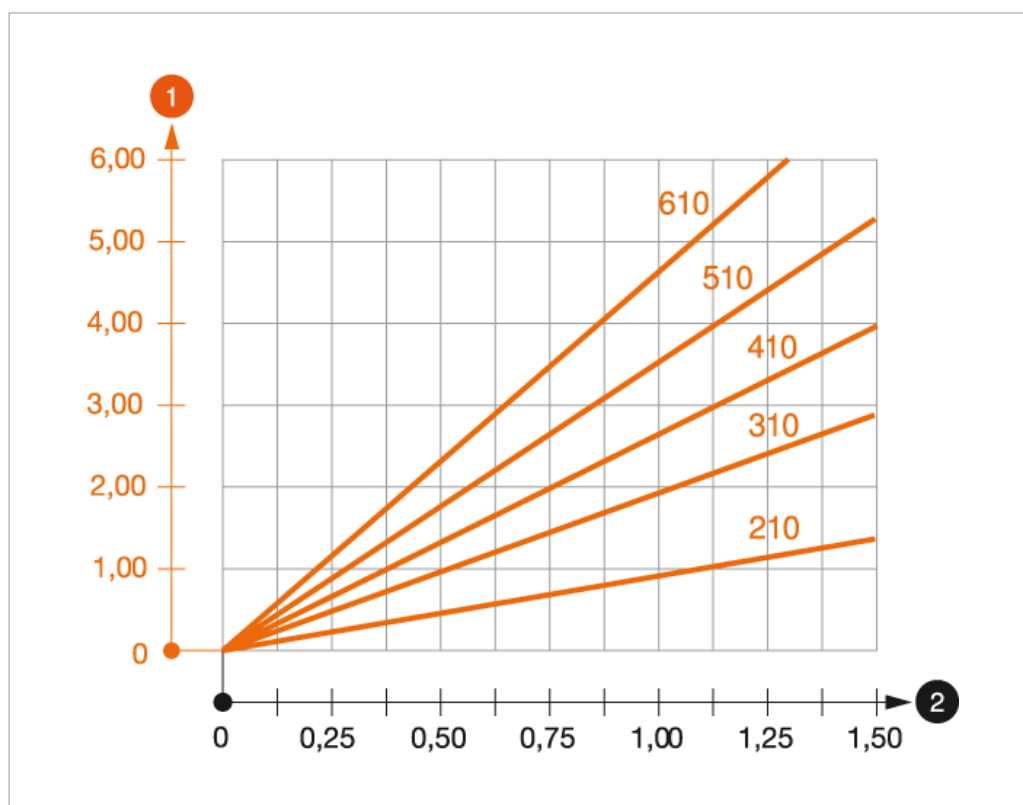

1 Bending of the bracket point at approved bracket load

2 Approved bracket load in kN without man load

— Load curve with bracket lengths in mm

Legend



Wall and support brackets



U support



U support



U support



Communautés Européennes, EC declaration of conformity according to EC directives



Verband der Elektrotechnik, Elektronik, Informationstechnik e.V., Germany